

ASSEMBLY AND MOUNTING INSTRUCTIONS – FORESITE DESIGNS®
TRASH RECEPTACLE, PARK AVENUE™ DESIGN 610001

PAGE 1

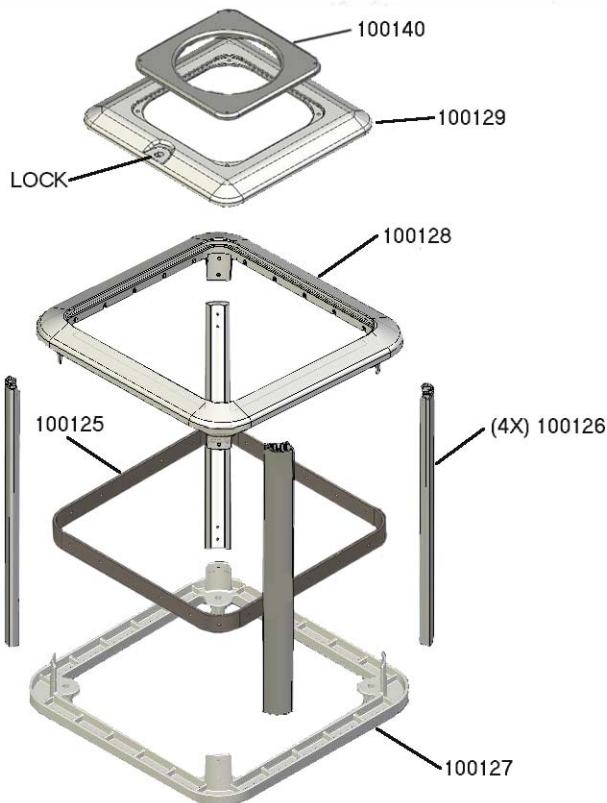
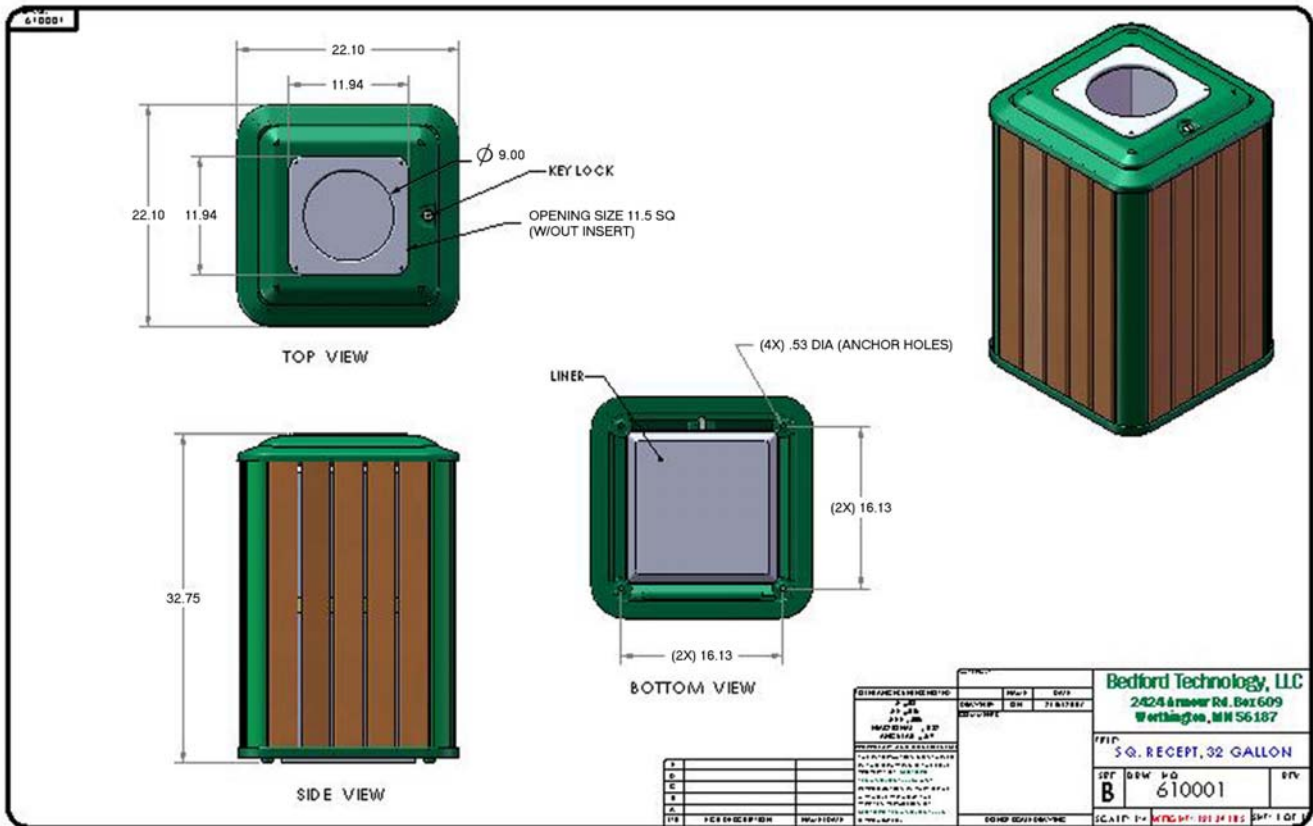

The drawing above shows the completed receptacle. Mounting holes (4) for anchoring the base of the receptacle to a pad or footing are dimensioned as shown in bottom view. The component parts of the trash receptacle are shown at left in an exploded diagram. Quantity is 1 each, unless noted differently. The plastic boards and liner are omitted for clarity. Components starting at the bottom and working up to the top are:

- 73-100127: base casting
- 73-100126: extruded upright (QTY 4)
- 73-100125: hoop, board mount
- 73-100128: top casting
- 73-100129: lid casting
- 71-1770A552: lock
- 73-100140: top insert (hole size varies)
- 71-0026: fastener kit (not shown)
- 71-LF20B: liner (not shown)
- 73-100124 plastic boards (QTY 20)

Assembly instructions for the trash receptacle are on the following pages.

Assembly Instructions PA6100 series; another person may be needed to assist

1. Lay out the components and make certain that all the parts are present. Find the base casting, 100127, and lay on flat surface with tabs being up (as shown).
2. Attach the extruded uprights, 100126, to the outside of the tabs at each corner of the base. Use the 1/4-20 X 5/8 Pan Head Screws through the tab and into the upright (2X) each corner location. Tighten screws just enough to hold uprights in place
3. Attach the hoop, 100125, to the inside of the four uprights using a 1/4-20 X 5/8 Pan Head Screw at each upright. Tighten screws just enough to hold position.
4. 73-100124 boards have 1 pre-drilled hole in end and one in middle. Place un-drilled end into a recessed pocket of the base casting, bring the board up against the hoop and use 10-3/4 pan head screw in pre-drilled hole to secure board to the hoop. Do all five boards on one side first. Just snug screws enough to hold board position. Install boards on the two adjoining sides next and the side opposite last.
5. Place the top casting onto uprights and settle it down against the board ends, making sure board ends are each seated in a recessed pocket of the top casting.
6. Secure the top casting to the uprights using the 1/4-20 X 5/8 Pan Head Screws. Don't fully tighten screws yet. Line up the assembly so everything is vertical and tighten the 1/4-20 screws on the top, hoop and base connections to the uprights. (May lay unit on its side to reach base screws)
7. Use 10-3/4 pan head screws through the slotted holes of the top casting flange into all the remaining boards. Tighten all screws in boards at casting and at the hoop.
8. Sit upright and seat the lid casting, 100129, into the recess of the top casting. Install the lock in the lid casting so it will hold the lid in place.
9. Install the insert, 100140, into the recess of the lid casting using 4 10-3/4 Pan Head Screws.
10. Mount the unit to concrete pad or footing using the anchor hole dimensions from bottom view of drawing to lay out the anchor bolt placement. May need to remove the lid casting for better access to mounting hardware. Secure the unit base to the anchors in the pad or footing.
11. Place the liner in the unit, lock down the lid casting and it is now ready for use.

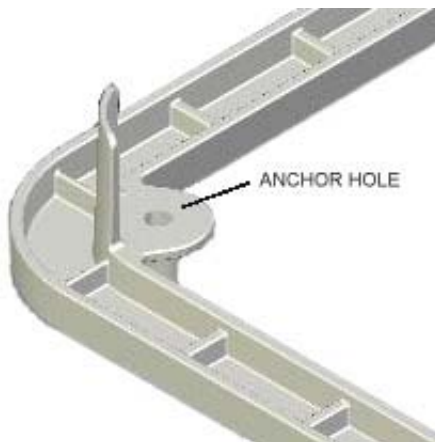

Use 3/8-1/2 inch diameter anchor bolt to secure the unit to the concrete. Slip the unit holes over the threaded shanks and use nuts and washers to tighten the base against the concrete surface. The base will sit slightly off the concrete surface because of the extension of the anchor housings. Anchors are not supplied

ASSEMBLY AND MOUNTING INSTRUCTIONS – FORESITE DESIGNS®
TRASH RECEPTACLE, PARK AVENUE™ DESIGN 610001

PAGE 3

| BILL OF MATERIAL – 610001 | | |
|----------------------------------|--------------------|------------|
| PART # | DESCRIPTION | QTY |
| 73-100127 | BASE CASTING | 1 |
| 73-100126 | EXTRUDED UPRIGHTS | 4 |
| 73-100125 | HOOP (BOARD MOUNT) | 1 |
| 73-100128 | TOP CASTING | 1 |
| 73-100129 | LID CASTING | 1 |
| 73-100140 | INSERT WITH HOLE | 1 |
| 71-0026 | FASTENER KIT | 1 |
| 71-LF20B | LINER | 1 |
| 71-1770A552 | LOCK | 1 |
| 73-100124 | 5/4 X 2 7/8 BOARDS | 20 |
| | | |