

ASSEMBLY AND MOUNTING INSTRUCTIONS – FORESITE DESIGNS
 8 FOOT SEAT, PARK SCAPE DESIGN 210001, 210002, AND 210003

PAGE 1

ASSEMBLY INSTRUCTIONS: SEAT 8 FOOT LENGTH 210001, 210002, and 210003

1. Unpack and lay out pieces to assemble. Verify that the parts, quantity, and dimensions match those on the enclosed bill of material.
2. Begin by placing two bull nose boards down on the ground or work area with curved side facing away from each other. Place the two rectangular boards between the two bull nose boards. Begin with one bull nose board and use other boards as working shims.
3. Place one weldment with plate having 8 drilled holes down against the boards and locate plate at a distance of 8 1/4 inches from plate side edge to end of bull nose and at a distance of 2 1/8 inches from plate end edge to flat side of bull nose. Use a hand square to line up plate on the bull nose surface. See diagram 1.
4. Drill 5/32 diameter pilot hole (two places) into the board and install two 1/4 x 2 screws into the board. (use end 2 holes in metal plate of weldment as a drill guide)
5. Place the second weldment with plate having 8 drilled holes down against the board and locate at a distance of 46 1/4 inches from plate side edge to same end of bull nose used in step 4 and at a distance of 2 1/8 inches from plate end edge to flat side of bull nose. See diagram 1.
6. Drill 5/32 diameter pilot hole (two places) into the board and install two 1/4 x 2 screws into the board. (use end 2 holes in metal plate of weldment as a drill guide)
7. Place the third weldment with plate having 8 drilled holes down against the board and locate at a distance of 84 1/4 inches from plate side edge to same end of bull nose used in step 4 and at a distance of 2 1/8 inches from plate end edge to flat side of bull nose. See diagram 1.
8. Locate one rectangular board at a distance of 8 1/4 inches from plate side edge to end of board and at a distance of 7 1/2 inches from extreme curved side of secured bull nose at both ends of rect. board. (Ref. 1/2 inch gap between sides of boards at each end.) See diagram 1.
9. Drill 5/32 diameter pilot hole (six places) into the board and install six 1/4 x 2 screws into the board. (use second line of 2 holes in metal plate of weldment as a drill guide)
10. Locate second rectangular board at a distance of 8 1/4 inches from plate side edge to end of board and at a distance of 11 1/2 inches from extreme curved side of secured bull nose at both ends of rectangular board. (Ref. 1/2 inch gap between sides of rectangular boards at each end.)
11. Drill 5/32 diameter pilot hole (six places) into the board and install six 1/4 x 2 screws into the board. (use third line of 2 holes in metal plate of weldment as a drill guide)
12. Locate second bull nose board at a distance of 8 1/4 inches from plate side edge to end of board and at a distance of 15 1/2 inches from extreme curved sides of two bull nose boards at both ends. (Ref. 1/2 inch gap between sides of rectangular boards at each end.)
13. Drill 5/32 diameter pilot hole (six places) into the board and install six 1/4 x 2 screws into the board. (use fourth line of 2 holes in metal plate of weldment as a drill guide)
14. Check square ness of seat before tightening screws.

DIAGRAM 1: SEAT 8 FOOT LENGTH PORTABLE 210003 SHOWN

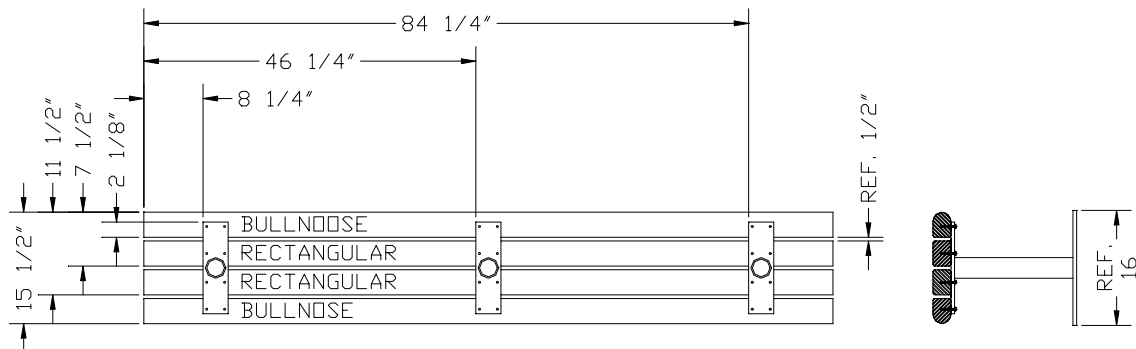

Turn to sheet two with diagram 2 for mounting instructions

ASSEMBLY AND MOUNTING INSTRUCTIONS – FORESITE DESIGNS
8 FOOT SEAT, PARK SCAPE DESIGN 210001, 210002, AND 210003
PAGE 2

MOUNTING INSTRUCTIONS: SEAT 8 FOOT LENGTH 210001, 210002, and 210003

1. Portable seat 210003 will rest on any flat, even surface-no mounting required
2. Surface mount seat 210001 mounts with ½ inch anchors into concrete surface at dimensions as shown on diagram 2.
3. Embedded mount seat 210002 mounts by setting in filled holes at dimensions as shown on diagram 2.

DIAGRAM 2: SEAT 8 FOOT LENGTH, SHOWN ARE
SURFACE 210001 CONCRETE ANCHORS 6 PLACES
EMBEDDED 210002 FILLED HOLES 3 PLACES

